

INSTALLATION, OPERATION, STORAGE AND MAINTENANCE INSTRUCTIONS FOR J.G. PAPAILIAS CO., INC. TYPE II WIPERS

1.0 Introduction

The PAPAILIAS, Inc. Type 2 Window Wiper assembly is designed for cleaning the lenses of PAPAILIAS Series NW circular weld pad style sight glasses. The Type 2 Window Wiper assembly is suitable for pressure conditions up to 225PSIG and Full vacuum.

The design features a manually actuated ratchet lever which turns the wiper blade using a flexible drive shaft.

The shaft passes through a gland system fitted into the weld pad and cover flange and is contained within a U-shaped tube on which the spring loaded wiper head is mounted.

NOTE: Check that the length of the wiper blade holder corresponds to the inside diameter of the fitting. If needed, the wiper blade holder and wiper blade can be trimmed prior to installation.



WARNING: No metal parts of the wiper unit should have direct contact to any part of the surface of the sight glass disc due, for example, eccentricity, missing or damaged gaskets, etc. Only use the specified, undamaged, original PAPAILIAS, Inc. parts. If in doubt cease all work and contact PAPAILIAS, Inc. immediately.

2.0 Inspection

PAPAILIAS, Inc. Type II Wipers should be inspected carefully for shipping damage. If damage is evident, do not attempt installation and notify the carrier immediately. If damage is only suspected consult factory before attempting installation.

3.0 Storage

Personnel handling Type II Wipers should have clean hands, free of dust, dirt, and grease. Type II Wipers

should be placed on clean surfaces, preferably covered with clean cloth or clean paper.

4.0 Installation and Maintenance

Installation should only be done by qualified personnel who are familiar with sight glasses or sight flow indicators and have read and understand all instructions contained herein and are also familiar with any available drawings depicting the sight glass assembly.

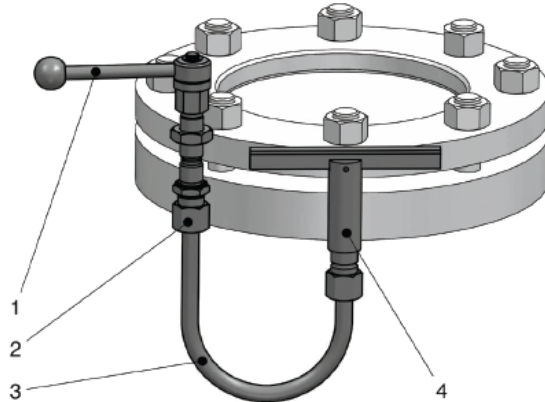

Item #	Description
1	Ratchet Lever
2	Threaded Gland
3	Guide tube for Flexible Shaft
4	Wiper Blade Holder and Blade

Before starting installation, the weld pad should be welded to the vessel in accordance with all relevant specifications and applicable codes. Once in place installation of the Type II Wiper assembly may begin.

1. Pull the flexible shaft [5] out of the guide tube [4].
2. Loosen gland nut [17a] from gland bushing [17b].
3. Thread the gland bushing [17b] into the threaded hole on the bottom of the weld pad flange and tighten. Insert the long end of the pre-assembled guide tube [4] into the gland bushing [17b]. Thread the gland nut [17a] tightly onto the gland bushing [17b], ensuring that the guide tube is precisely centered in the middle of the weld pad flange.
4. Insert the flexible shaft [5] which is shipped shop assembled and includes part numbers [2], [3], [7], [8], [12], [13], [15] and [16] into the guide tube [4] and tighten slightly by screwing in the threaded bushing [2] using a spanner wrench. Prior to tightening it fully, check if the gland seal [13] is correctly positioned

INSTALLATION, OPERATION, STORAGE AND MAINTENANCE INSTRUCTIONS FOR TYPE II WINDOW WIPERS

between the gland bushing and the threaded bushing [17b and 2].

5. Insert the springs [11] into the guide bushing of the guide tube [4] [if the springs are not already properly positioned in the wiper head].

6. Attach the wiper arm [1] on the guide bushing of the guide tube [4] in such a way that the square end of the wiper arm receptacle can be easily positioned over the square hub of the flexible shaft [5].

7. Test the assembly using the handle of the operating lever [3] clockwise. When viewed from above this should rotate the wiper blade in the counter-clockwise direction. Always take care to ensure that the wiper blade holder runs concentrically within the weld pad flange. The gland nut [17a] can be loosened and adjusted if necessary to make this happen.

8. If the drive shaft runs too easily [loose] or with too much difficulty [tight] the threaded bushing [2] can be tightened or loosened at the hexagon nut and then locked by tightening the flat hexagon nut [12].

9. Once the test is complete and all necessary adjustments are made remove the circlip [15] and the washer [16] with the operating lever [3] from the drive shaft, leaving the spacer sleeve [8] in place. Final assembly of the sight glass may now take place.

10. Before starting installation of the lens and lens retainer it is imperative that the manual covering your particular sight glass is on hand. If it unavailable please visit www.papailias.com or contact the factory.

11. The lens should be examined for scratches and other imperfections. Use a flashlight or other bright concentrated light to examine the lens carefully. If any type of flaw is apparent, installation should be delayed pending the replacement of the item.

DANGER: Lenses that have scratches or other imperfections are weakened and should not be used under any circumstance.

12. Make sure that all gaskets and sealing surfaces are absolutely clean and free of any particles or dirt. Place the seal gasket into the counter-bore of top surface of weld pad [tank side] flange followed by the sight glass lens. Position the top gasket and the cover flange on top.

13. Align the drilled hole for the wiper mechanism in the cover flange directly over the hole in the weld pad so that the operating lever and the drive shaft can function smoothly and unobstructed.

14. Re-mount the operating lever [3] and replace the washer [16] and circlip [15]. Once more take care to ensure that the wiper blade holder runs concentrically within the weld pad flange. The gland nut [17a] can be loosened and adjusted if necessary.

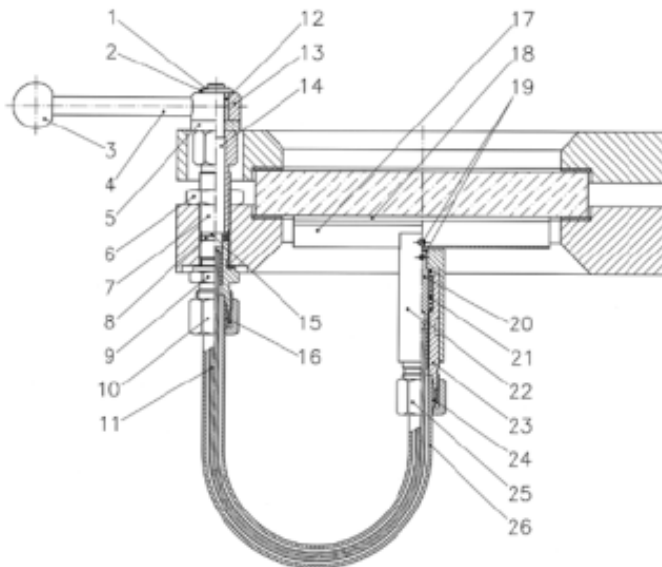

Item	Part	Item	Part
1	Clip	15	Washer, Galvanized Steel
2	Washer	16	Compression Ring, T316/316L SST
3	Phenolic Knob [Brass Bushing]	17	Blade Holder, T316/316L SST
4	Drive Lever Arm, T303 SST	18	Wiper Blade, Silicone or PTFE
5	Spacer Ring, T303 SST	19	Groove Pin, T316/316L SST
6	Locknut	20	Blade Holder Axle, T316/316L SST or UNS S31600 / UNS S31603
7	Threaded Bushing, T304/304L SST	21	Spring, AISI 301 SST
8	PTFE Packing	22	Blade Holder Shroud, T316/316L SST or UNS S31600 / UNS S31603
9	Retaining Bushing, T316/316L SST	23	Guide Post, T316/316L SST
10	Compression Nut, T316/316L SST	24	Compression Ring, T316/316L SST
11	Flexible Drive Shaft, T301 SST or UNS S31600 / UNS S31603	25	Compression Nut, T316/316L SST
12	Ratchet Drive Bearing, Steel	26	Guide Tube, T316/316L SST
13	Bearing Boss, T303 SST		
14	Drive Shank, T303 SST		